

PRODUCT INFORMATION PACKET

marathon[®]
Motors

Model No: 184TTFN6555
Catalog No: U868A
5,1800,TEFC,184T,3/60/230/460
Cooling Tower



Regal and Marathon are trademarks of Regal Beloit Corporation or one of its affiliated companies.
©2018 Regal Beloit Corporation, All Rights Reserved. MC017097E

REGAL[®]



Nameplate Specifications

Output HP	5 Hp	Output KW	3.7 kW
Frequency	60 Hz	Voltage	230/460 V
Current	12.4/6.2 A	Speed	1755 rpm
Service Factor	1.15	Phase	3
Efficiency	90.2 %	Duty	Continous
Insulation Class	F	Design Code	B
KVA Code	J	Frame	184T
Enclosure	Totally Enclosed Fan Cooled	Overload Protector	No
Ambient Temperature	40 °C	Drive End Bearing Size	6206
Opp Drive End Bearing Size	6206	UL	Recognized
CSA	Y	CE	Y
IP Code	55		

Technical Specifications

Electrical Type	Squirrel Cage Induction Run	Starting Method	Across The Line
Poles	4	Rotation	Reversible
Mounting	Rigid base	Motor Orientation	Horizontal
Drive End Bearing	Ball	Opp Drive End Bearing	Ball
Frame Material	Cast Iron	Shaft Type	T
Overall Length	17.87 in	Frame Length	10.00 in
Shaft Diameter	1.125 in	Shaft Extension	2.9 in
Assembly/Box Mounting	F1/F2 Capable		
Outline Drawing	035661-1000	Connection Diagram	EE7308

This is an uncontrolled document once printed or downloaded and is subject to change without notice. Date Created: 06/29/2018

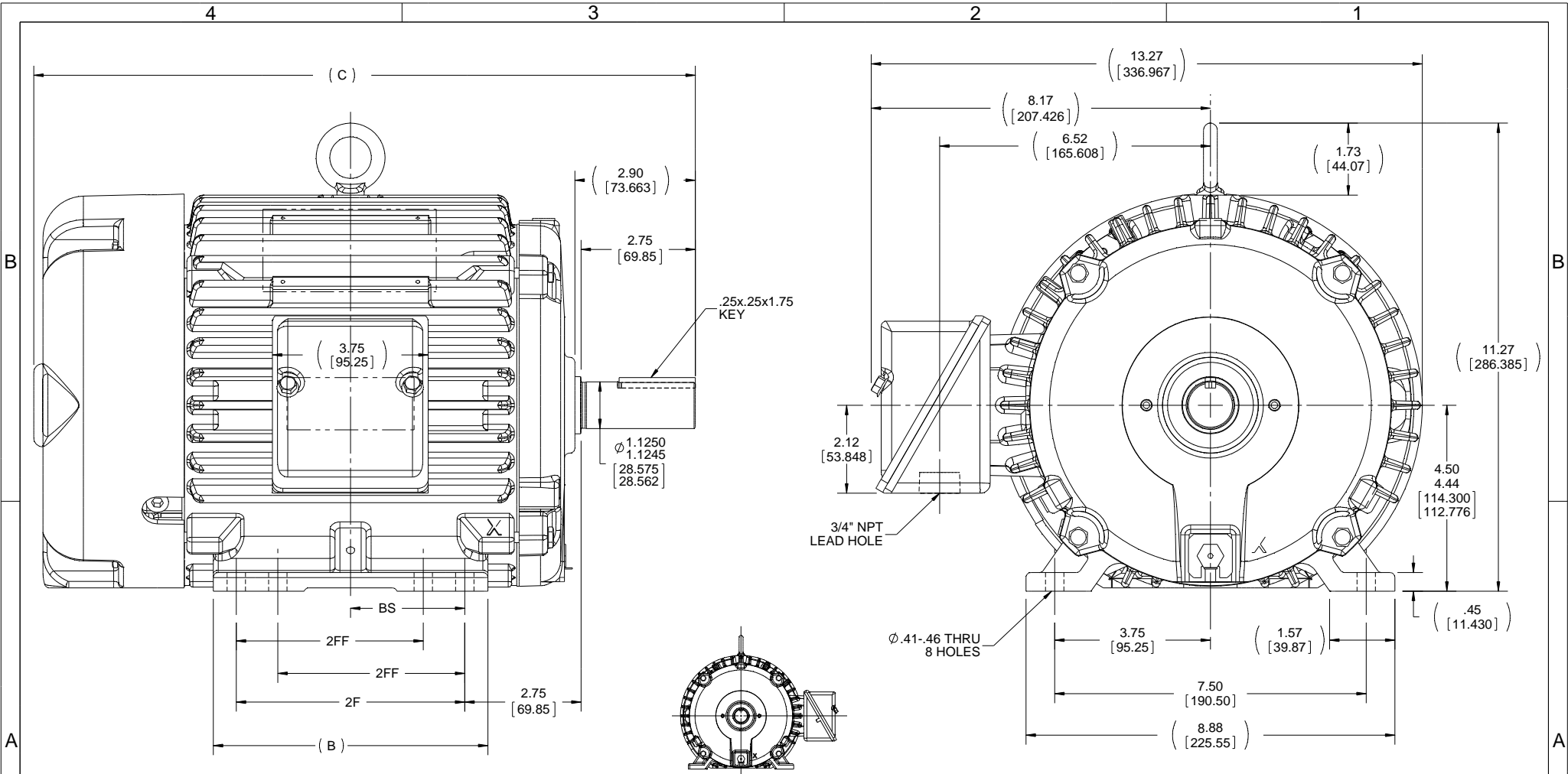

- NOTES:
 1. NAMEPLATE TO BE READ FROM CONDUIT BOX SIDE OF MOTOR.
 2. CONDUIT BOX CAN ROTATED IN 90° STEPS.
 3. CONDUIT BOX CAN BE MOUNTED ON OPPOSITE SIDE BY REMOVING BRACKETS AND TURNING FRAME 180°

F2 VIEW

1000	182/184	17.87	8.61	7.50	5.50	3.75
800	182/184	15.87	6.61	5.50	4.50	2.75
DASH	FRAME	C	B	2F	2FF	BS

DRAWING REVISION D	REVISION BY PVR	DATE 05/13/15
ECO ECO-0077554	APPROVED BY ST	DATE 05/13/15
ECO DESCRIPTION F2 VIEW ADDED		
<small>COPYRIGHT REGAL BELOIT AMERICA, INC. ALL RIGHTS RESERVED. PROPRIETARY AND CONFIDENTIAL INFORMATION - THIS DOCUMENT IS THE PROPERTY OF REGAL BELOIT AMERICA, INC. (OWNER) AND CONTAINS OWNER'S PROPRIETARY INFORMATION. ANY PERSON, CORPORATION OR OTHER FIRM RECEIVING IT IS DEEMED, BY RECEIVING IT, TO AGREE THAT IT, AND/OR ANY PART OF IT, SHALL NOT BE DISCLOSED TO ANY PERSON, CORPORATION OR OTHER ENTITY, DUPLICATED, AND/OR USED, EXCEPT AS EXPRESSLY APPROVED IN WRITING IN ADVANCE BY OWNER. THIS DOCUMENT SHALL BE RETURNED TO OWNER UPON REQUEST. IT MAY BE SUBJECT TO CERTAIN RESTRICTIONS UNDER APPLICABLE EXPORT CONTROL LAWS AND REGULATIONS.</small>		

TOLERANCES UNLESS OTHERWISE SPECIFIED:			
DEC	INCH	mm	ANGLE
.X	+0.1	[+2.5]	±7 30°
.XX	±0.03	[±0.76]	
.XXX	±0.005	[±0.127]	
.XXXX	±0.0005	[±0.0127]	
REMOVE BURRS & BREAK SHARP EDGES: .003/.015 [.076/.381] X 45°			
CORNER FILLETS: R.02 [.51]			
MACHINED SURFACES: 200 INCH 5.1 mm			
mm SHOWN IN [BRACKETS]			

DRAWN BY TJW 3/25/2008
DATE
APPROVED BY SW 3/26/2008
DATE
REFERENCE
THIRD ANGLE PROJECTION

Regal Beloit America, Inc.	
DESCRIPTION	OUTLINE 180 FR. - CAST C'BOX
MATERIAL	PROCESS/FINISH
SIZE B	DRAWING NUMBER 035661
	SHEET 1 OF 1

EE7308

THREE PHASE
DUAL VOLTAGE MOTOR



VIEW OF TERMINAL END

REF.
WINDING DIAGRAM

T8Y, T2Y, T2BL, T4BX, T2EC, T2G
T6BZ, T2B, T6BL, T4AV, T6B, T4B

OPTIONAL CORD
CONNECTION

L1 — WHITE
L2 — RED
L3 — BLACK

NO.	REVISION	BY & DATE	CHK	ANG	TOLERANCES UNLESS SPECIFIED		FINISH	DRAWN RM 11/20/1990				
					DEC.	INCHES						
5	CHG TO REGAL LOGO	SL 09/10/2015	AB					CHK ML 11/21/1990				
4	REVISED IEC NOTATIONS	MSG 11/15/2011	CMN	.X	±.1			APPD SAS 04/24/2003				
3	ADDED IEC NOTATIONS... (U1), (V1) ETC. MU95194	MSG 5/10/2010	MJS	.XX	±.02			SCALE 1=1				
2	ADDED THE OPTIONAL CORD CONNECTION MU46318	RDH 04/24/2003	DRS	.XXX	±.005		TITLE CONNECTION DIAGRAM 3Ø - DUAL VOLTAGE MOTOR	REF				
1	REDRAWN	RM 11/20/1990		.XXXX	±.0005		MAT'L.	FMF				
					±7'30"			PREV				
THIS DRAWING IN DESIGN AND DETAIL IS OUR PROPERTY AND MUST NOT BE USED EXCEPT IN CONNECTION WITH OUR WORK ALL RIGHTS OF DESIGN AND INVENTION ARE RESERVED THIS IS AN ELECTRONICALLY GENERATED DOCUMENT - DO NOT SCALE THIS PRINT							RFP	CAD FILE ee7308	SIZE A	DRAWING NO. EE7308	PAGE OF 5	REV. 5
							DIST WP					



CERTIFICATION DATA SHEET

Model#: 184TTFN6555 AA **WINDING#:** K1844215 NONE 1
CONN. DIAGRAM: EE7308 **ASSEMBLY:** F1/F2 CAPABLE
OUTLINE: 035661-1000

TYPICAL MOTOR PERFORMANCE DATA

HP	KW	SYNC. RPM	F.L. RPM	FRAME	ENCLOSURE	KVA CODE	DESIGN
5&3	3.7&2.24	1800	1755&1465	184T	TEFC	J	B

PH	Hz	VOLTS	FL AMPS	START TYPE	DUTY	INSL	S.F	AMB°C	ELEVATION
3	60/50	230/460#190/ 380	12.4/6.2&9.6/4 .8	ACROSS THE LINE	CONTINUOU S	F3	1.15/1.15	40	3300

FULL LOAD EFF: 90.2&90.2	3/4 LOAD EFF: 90.2	1/2 LOAD EFF: 90.2	GTD. EFF	ELEC. TYPE	NO LOAD AMPS
FULL LOAD PF: 83.5&79	3/4 LOAD PF: 78.5	1/2 LOAD PF: 70	89.5	SQ CAGE IND RUN	5.6 / 2.8

F.L. TORQUE	LOCKED ROTOR AMPS	L.R. TORQUE	B.D. TORQUE	F.L. RISE°C
15 LB-FT	92 / 46	34.5 LB-FT 230	45 LB-FT 300	50

SOUND PRESSURE @ 3 FT.	SOUND POWER	ROTOR WK^2	MAX. WK^2	SAFE STALL TIME	STARTS /HOUR	APPROX. MOTOR WGT
62 dBA	72 dBA	0.5 LB-FT^2	50 LB-FT^2	25 SEC.	2	130 LBS.

***** SUPPLEMENTAL INFORMATION *****

DE BRACKET TYPE	ODE BRACKET TYPE	MOUNT TYPE	ORIENTATION	SEVERE DUTY	HAZARDOUS LOCATION	DRIP COVER	SCREENS	PAINT
STANDARD	STANDARD	RIGID	HORIZONTAL	PREMIUM SEVERE DUTY	NONE	FALSE	NONE	BLUE (EPOXY)

BEARINGS		GREASE	SHAFT TYPE	SPECIAL DE	SPECIAL ODE	SHAFT MATERIAL	FRAME MATERIAL
DE	OPE						
BALL	BALL	POLYREX EM	T	NONE	NONE	1144 STRESSPROOF (C-223)	CAST IRON
6206	6206						

THERMO-PROTECTORS				THERMISTORS	CONTROL	SPACE /n HEATERS
THERMOSTATS	PROTECTORS	WDG RTDs	BRG RTDs			
NONE	NOT	NONE	NONE	NONE	FALSE	NONE VOLTS

If Inverter equals NONE, contact factory for further information

*
N
O
T
E
S
*

INVERTER TORQUE: NONE
INV. HP SPEED RANGE: NONE
ENCODER: NONE
NONE NONE
NONE NONE PPR
BRAKE: NONE NONE
NONE P/N NONE
NONE NONE
NONE FT-LB NONE V NONE Hz

DATE: 06/28/2017 07:22:24 AM
 FORM 3531 REV.3 02/07/99

** Subject to change without notice.

Data Sheet

Date: 19-06-2017
 Customer: _____
 Attention: _____
 Submitted by: FAREEDA DUDEKULA



184TTFN6555

Submittal

Data @ 460 V

Motor Load Data

Load	0%	25%	50%	75%	100%	115%	125%	LR
Current (Amps)	2.80	3.0	3.8	5.0	6.2	7.2	7.8	46.0
Torque (ft-lb)	0.00	3.7	7.4	11.5	15.0	17.5	19.0	34.5
RPM	1800	1790	1780	1765	1755	1,745	1740	0
Efficiency (%)		85.5	90.2	90.2	90.2	89.5	88.5	
P.F. (%)	6.5	47.0	70.0	78.5	83.5	84.5	86.0	48.0

Motor Speed Data

	LR	Pull-Up	BD	Rated	Idle
Speed (RPM)	0	900	1600	1755	1800
Current (Amps)	46.0	41.0	25.0	6.2	2.80
Torque (ft-lb)	34.5	31.0	45.0	15.0	0.00

Information Block

HP	5.0			
Sync. RPM	1800			
Frame	184			
Enclosure	TEFC			
Construction	TFN			
Voltage	30/460#190/38V			
Frequency	60 Hz			
Design	B			
LR Code letter	J			
Service Factor	1.15			
Temp Rise @ FL	50 ° C			
Duty	CONT			
Ambient	40 ° C			
Elevation	1,000 feet			
Rotor/Shaft wk ²	0.50 Lb-Ft ²			
Ref Wdg	K1844215 NONE			
Sound Pressure @ 1M	62 dBA			
VFD Rating	NONE			
Outline Dwg	035661-1000			
Conn. Diag	EE7308			
Additional Specifications:				
0				
365THFS8036				
EQUIV CKT (OHMS / PHASE)				
R1	R2	X1	X2	Xm
1.5080	1.1280	3.6910	5.6930	104.3280

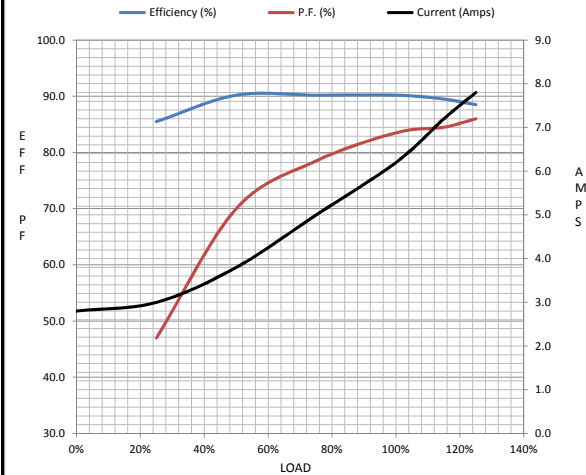

Speed -Torque Curve

